

# Multi-Axis Tilt Platform

**6TP116**



**Multi-Axis Tilt Platform 6TP116** provides angular adjustment about two-axis – tilting and in-plane rotation. The mounting platform is rotated around kinematic pivot point by two micrometers. The out-of-plane tilting range is  $\pm 2^\circ$  and the in-plane rotation ranges is  $\pm 2.5^\circ$ . Two micrometer screws are located side by side for a handy use. The adjustment movements are not calibrated, and they are uncoupled.

The mounting platform has a **25 mm** grid of tapped holes **M6** and **M4**. Two clearance holes  $\varnothing 6.2$  are provided in the base of the unit. This allows to attach **6TP116** to tables and breadboards. Also you can clamp the base of the unit by **STANDA Table Clamp 3TC5**; this way you can orient the unit on the table in any direction. The tilt platform is made of black anodized aluminium.

**SPECIFICATIONS**

Tilt $\Theta_y$	$\pm 2^\circ$
Rotation $\Theta_z$	$\pm 2.5^\circ$
Load capacity	15 kg
Weight	1 kg

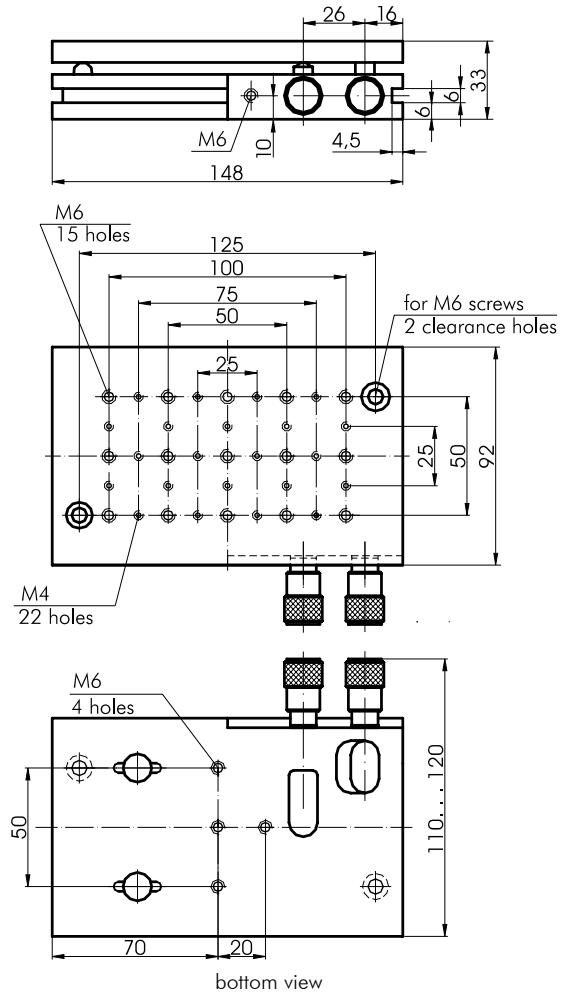

## Available Motorized version 8MTP116



**SPECIFICATIONS**

Tilt $y$	$\pm 2^\circ$
Rotation $z$	$\pm 2.5^\circ$
Resolution	
in full step	1.25 $\mu\text{m}$
in 1/8 step	0.156 $\mu\text{m}$
Lead screw pitch	0.25 mm
Repeatability	1 $\mu\text{m}$
Maximum load capacity	10 kg
Type of actuator	8CMA28-10
Cable	1.2 m length cable included
Motor connector	DB15(M)
Weight	1.3 kg

## Tilt/Rotation Stage

6PT110

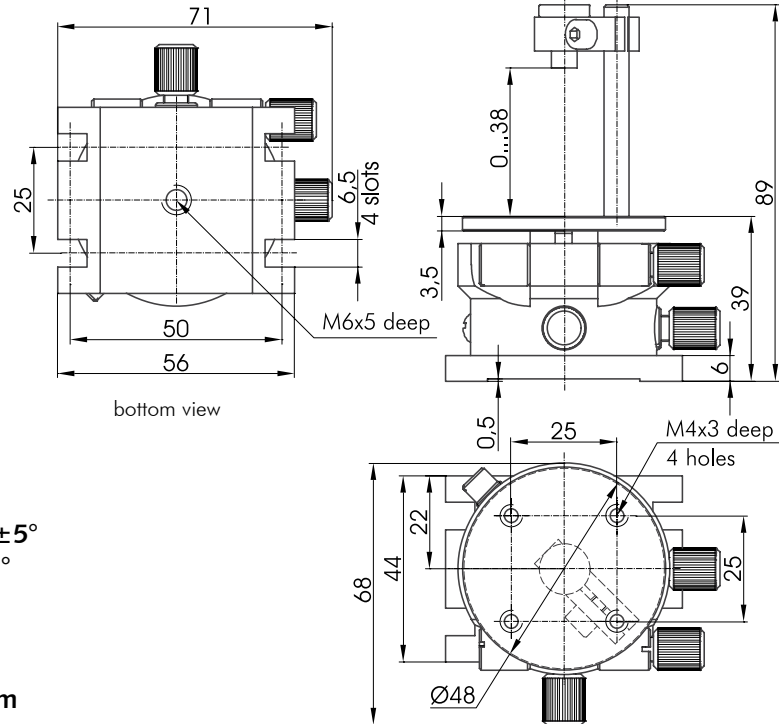

- in-plane rotation in the range of  $\pm 5^\circ$
- tilt of two axis in the range of  $\pm 5^\circ$
- precision screws are included
- spring-loaded mounting clamp
- stage could be easily mounted
- maximal component height 38 mm

**Tilt / rotation stage 6PT110** provides **two independent tilt adjustments** within  $\pm 5^\circ$  range and  **$\pm 5^\circ$  in-plane rotation adjustment**. Precision screws provide **9 arcsec** resolution in rotation and both tilt planes (adjustment screws **M6x0.25**, 3 pcs.). The mounting clamp with a spring-loaded disengagement knob allows easy insertion and removal of **optical components** up to **38 mm** height and **30x30 mm** in square. Stage is attached to tables through clearance holes in its base. The main elements of the stage are finished with **black anodized aluminium**.

## SPECIFICATIONS

Tilt $\Theta_x$ and $\Theta_y$	$\pm 5^\circ$
Rotation $\Theta_z$	$\pm 5^\circ$
Weight	0.23 kg

## Adjustable Laser/Laser Head Holder

6LH



- Stable design
- Precise adjustment about linear and angular coordinates

- Wide adjustment angle
- High load capacity
- Convenient mounting

*4 adjustable degrees of freedom!*

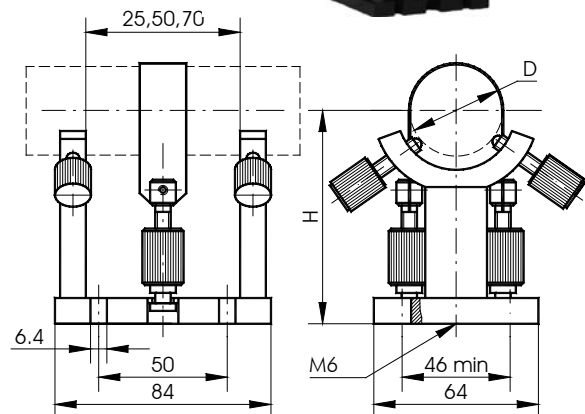

**Adjustable Laser/Laser Head Holder 6LH** is used for repeatable mounting and drift-free pointing of laser heads and other cylindrical objects.

You may easily reposition the two supports to select an optimal **basis** for cylindrical objects of

differing lengths (basis of 25, 50, or 70 mm).

**6LH** is made of black anodized aluminium and is equipped with **6.4 mm** clearance slots and **M6** tapped holes to attach to **STANDA** tables and breadboards.

Model	D, mm	H, mm	Weight, kg
6LH-25	Ø25 - Ø36	≈75	0.26
6LH-50	Ø48 - Ø55	≈65	0.20

# Three Angle Prism/Beamsplitter Table

**6PT169**



- Three degrees of freedom with common centre of rotation
- For precision alignment of prisms, beamsplitters, etc.
- Mounts horizontally or vertically



**Three Angle Prism/Beamsplitter Table 6PT169** provides non-calibrated tilt motion in three planes. It is ideal work platform for prisms, beamsplitters and mirrors, which need to be precisely adjusted in angle about three orthogonal axes. Various optomechanical mechanisms can be quickly and conformably attached to the top of the table stage using Spring Clamps 4SC. Prisms can be fixed to the top of the Table using Bar Clamp 4BC32 or V-Clamp 4VC41.

Every Three Angle Prism/Beamsplitter Table 6PT169 is provided with three drives ensuring rotation about three different axis. Two lower screws turns the top of the table around two orthogonal horizontal axes, upper screw ensures rotation around vertical axe in plane. All three rotations are fully independent and all three axes are full orthogonal. Fine pitch screw threads ensure high resolution and strong springs provide a stable platform. All three rotations are about a point 27 mm below the centre of the top plate.

Three Angle Prism/Beamsplitter Table 6PT169 can be attached to STANDA optical table or to another stages with Table Clamp 3TC5. Also four attachment thread M6 holes in the bottom of the table are provided. The main elements of the table are made from black anodized aluminium.

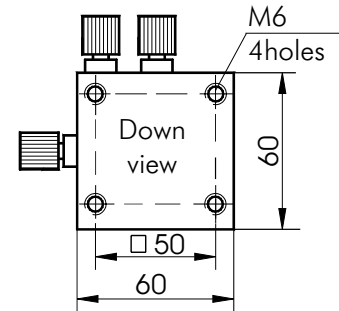
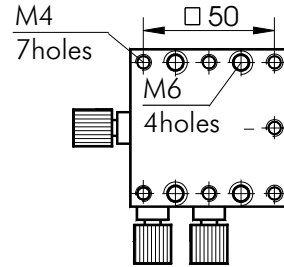
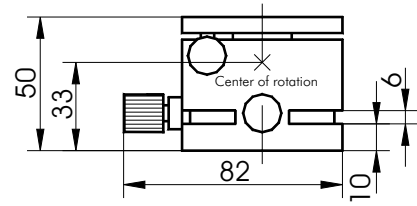

methods of fastening:  
by the holes,  
and by a clamp

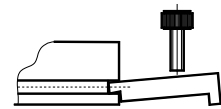

**SPECIFICATIONS**

Tilt $\Theta_x$ and $\Theta_y$	$\pm 4^\circ$
Rotation $\Theta_z$	$\pm 4^\circ$
Sensitivity	8 arcsec
Weight	0.43 kg
Hole pattern	$4 \times M6$ ; $7 \times M4$

# Single-Axis Tilt Stage

**6TS**



A **Single-Axis Tilt Stage 6TS** provides **tilt** range of  $6^\circ$  with  $6 \mu\text{rad}$  sensitivity. Pivot is done on two hardened steel balls.

The base has **M6** tapped holes on four sides, to fasten the platform, for example on mounting posts **3MP**.

Material – black anodized aluminium.

Weight: **6TS62** – 0.11 kg  
**6TS72-72** – 0.16 kg

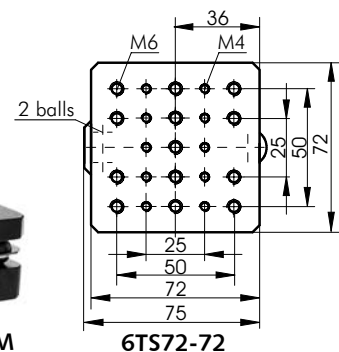
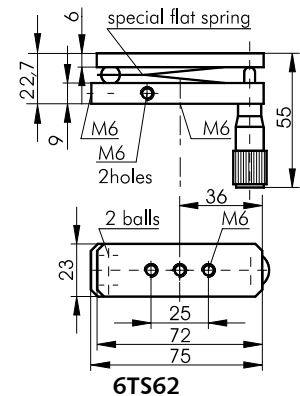

**Examples of order codes**

6TS62 (6TS72-72)

6TS62-9S67M (6TS72-72-9S67M)

6TS62-9S127M (6TS72-72-9S127M)

See **section 9** for screws. **The platform of other dimensions is available.**

**fine driving screw**

9S65M (comes as standard – omit the screw code)

9S67M (alternative screw – append the code)

9S127M-10



# Tilt Stage

## 6TS29-21

- Tip/tilt range of  $\pm 3^\circ$
- Compatible with 7T25-10 series
- Material: black anodized aluminium



**NEW**

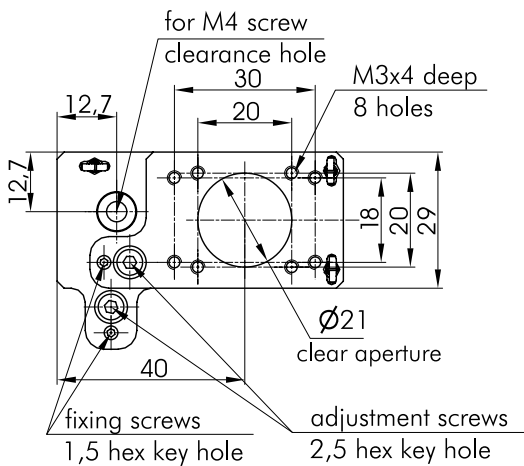
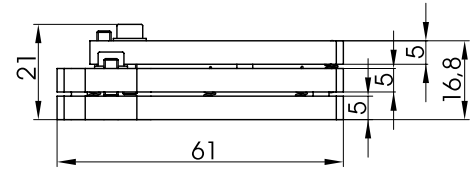
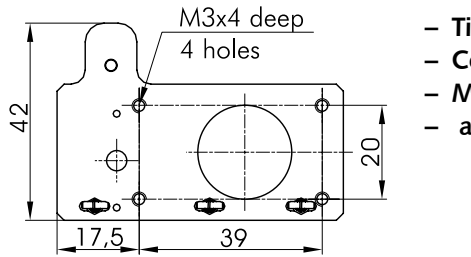

### SPECIFICATIONS

Tilt $\Theta_x$ and $\Theta_y$	$\pm 3^\circ$
Load capacity	1.5 kg
Weight	0.025 kg

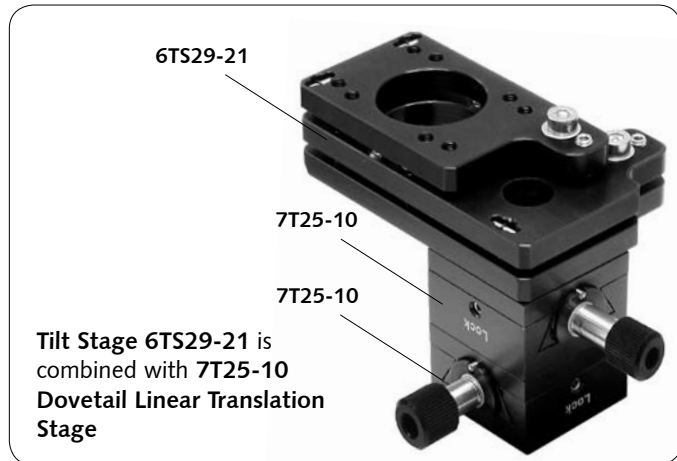

Tilt Stage 6TS29-21 is combined with 7T25-10 Dovetail Linear Translation Stage

http://www.standa.it

e-mail: sales@standa.it

Fax: +370-5-2651483

Phone: +370-5-2651474

# Roll & Pitch Tilt Platform

## 7FA3

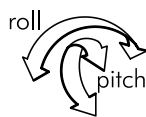

- Tilt (roll & pitch) platform
- Travel in z axis: -2 mm, +4 mm
- Travel roll, pitch  $\pm 4^\circ$
- Resolution 10 arcsec
- Compatible with 7TF2

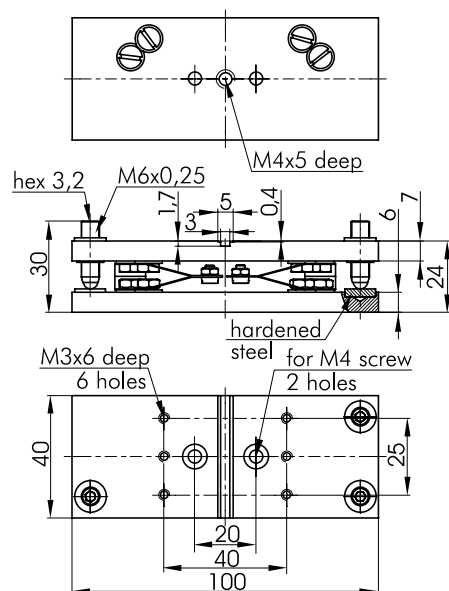

**standa**

- Optical Tables 1
- Brackets & Rails 2
- Base Mounts & Accessories 3
- Optical Mounts 4
- Optical Positioners 5
- Base Positioners 6
- Translation & Rotation Stages 7
- Motorised Positioners & Controllers 8
- Fine Adjustment Screws 9
- Opto-Mechanics & Sets 10
- Light Test & Measurement Instruments 11

# Pitch & Yaw Platform

**7FA5**



- Pitch yaw platform
- Yaw  $\pm 4^\circ$
- Pitch  $\pm 3^\circ$
- Resolution 10 arcsec
- Compatible with 7TF2

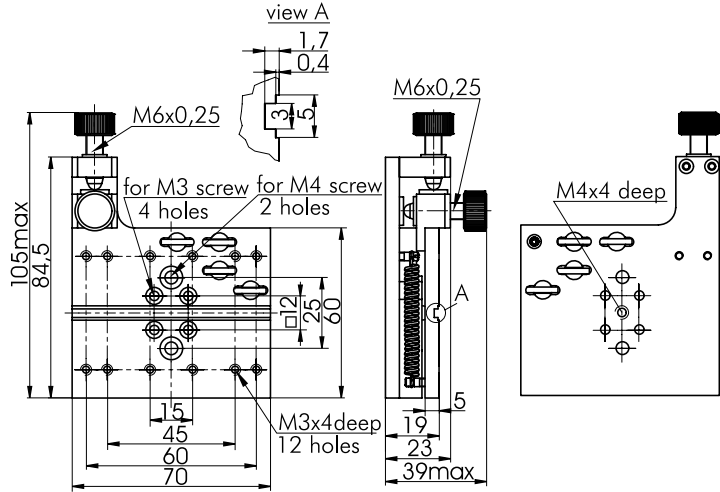
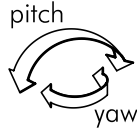

## TWO-AXIS TILT PLATFORMS

APPLICATION SUGGESTIONS



50M10T  
with  
50M100A2/50M100B1



5UM122  
with  
3MP/3RBP



50M122T  
with  
50M122A2/50M122B2



50M101T  
with  
3MP/3PH/3CMB



50M60  
with  
3MP/3PH/3BP4



50M37-20  
with  
3MP/3PH/3CMB

e-mail: sales@standa.it

http://www.standa.it

Phone: +370-5-2651474

Fax: +370-5-2651483

# Kinematic Bases

## 6KB131 • 6KB31



6KB131

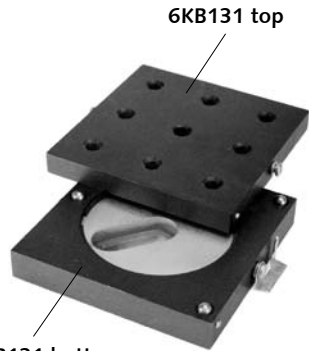

6KB131 bottom

6KB131

- Kinematic repositioning with repeatability of several arcsec
- Exclusive mounting disk for extra freedom in positioning (6KB131 only)
- Hooks of spring steel for reliable locking and quick-release

A kinematic base is used for repeated positioning of groups of units mounted on its platform.

A platform has M6 mounting holes. Alternatively, fit an M6 screw through a clearance hole from beneath.

You unhook the platform from the bottom plate and stow it away with all the units still mounted.

Later you **replace** the platform, just as it was, with a **repeatability of several arcsec**.

The bases use a kinematic scheme, where three steel balls register with a cone, a v-groove, and a flat. The balls and registers are of hardened polished steel.

**Hooks** of spring steel prevent accidental movement platform .

Bottom plate is fastened through clearance holes or a slot. **6KB131** has a revolving mounting disk – a degree of freedom of positioning.

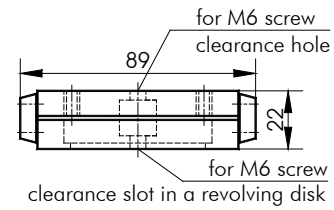

for M6 screw clearance slot in a revolving disk

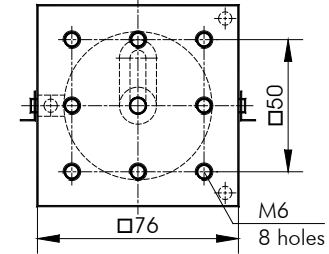

6KB131

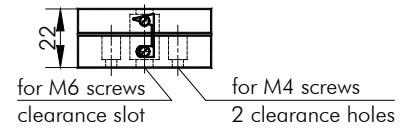

for M6 screws clearance slot for M4 screws 2 clearance holes

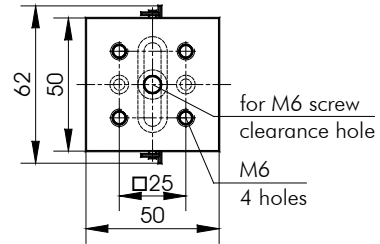

6KB31

### SPECIFICATIONS

Material	Aluminium
Finish	Black anodized
Weight	
6KB31	0.14 kg
6KB131	0.30 kg

# Magnetic Kinematic Base

## 6MKB175



6MKB175

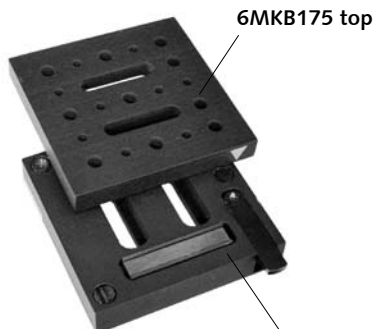

6MKB175 bottom

You lift the units mounted on the platform as a group. The platform is **replaced** with a **repeatability of 50 μm**.

The platform has patterns of M4 and M6 mounting holes. Alternatively, fit M6 screws through its clearance slots from beneath.

Two high strength **magnets** lock the platform to the bottom plate.

The bottom plate is fastened by M6 screws through a pair of transversal clearance slots.

Push the special **lever** to **lift** the platform with minimal jolts.

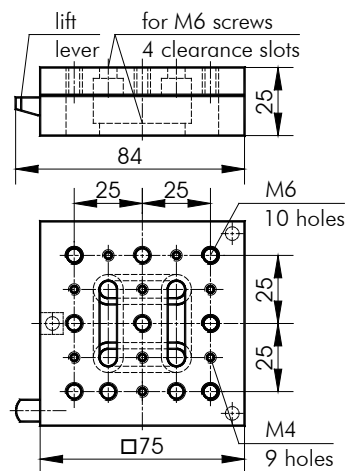

### SPECIFICATIONS

Material	Aluminium
Finish	Black anodized
Weight	0.36 kg

http://www.standa.it

e-mail: sales@standa.it

Phone: +370-5-2651483

Fax: +370-5-2651474

standa

- Optical Tables 1
- Brackets & Rails 2
- Base Mounts & Accessories 3
- Optical Mounts 4
- Optical Positioners 5
- Base Positioners 6
- Translation & Rotation Stages 7
- Motorised Positioners & Controllers 8
- Fine Adjustment Screws 9
- Opto-Mechanics & Sets 10
- Light Test & Measurement Instruments 11