

Universal Motorized Rotation Stages

8MRU

NEW

Universal motorized rotation stage 8MRU is a simple and durable low cost solution for use as optical element rotator, filter wheel or universal rotating platform.

Centre opening has a threaded M27x1 aperture for mounting 1" optical elements. Retaining ring for fastening optics is included.

8MRU with various accessories can serve as several devices in one.

SPECIFICATIONS

Rotation range	360°
Resolution in full step	0.6°
in 1/8 step	4.5 arcmin
Max. rotation speed*	3 ÷ 5 rps
Wobble	2 arcmin
Reduction gear	3:1
Limit switches	mechanical
Drive mechanism	belt
Load capacity	
Horizontal	5 kg
Radial	1.5 kg
Torque	4.5x10 ⁻³ Nm
Cable	integrated, 1.6 m length
Motor connector	HDB15(M)
Stepper motor	28S

***Test condition:**
 • STANDA controllers;
 • Power supply – 36V.

Custom accessories are manufactured on request!

Universal Motorized Rotation Stage

8MRU-1

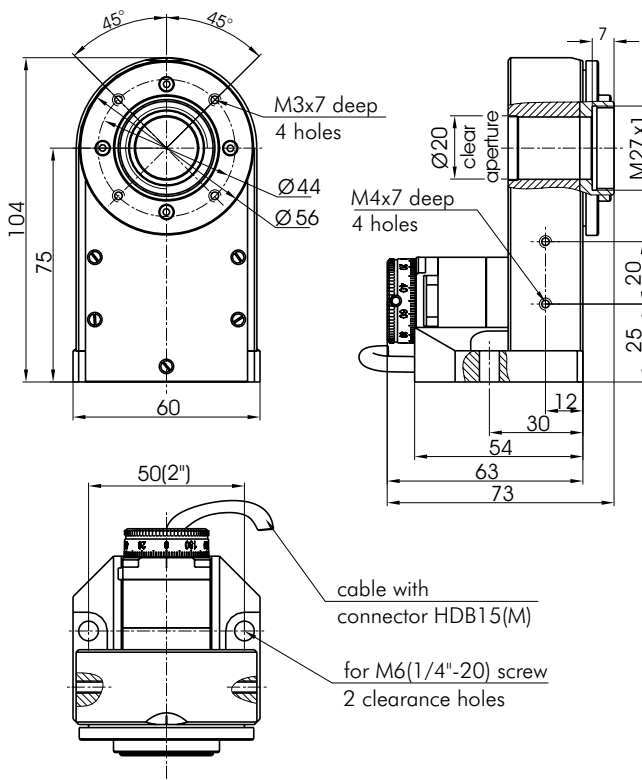

8MRU-1 is a basic rotation stage that can rotate 1" optical elements. Various accessories and custom parts can be mounted on provided M3x7 mounting holes.

Variations of 8MRU-1 with accessories for various applications can be seen below.

Weight 0.55 kg

Universal Motorized Rotation Stage

8MRU-1WA

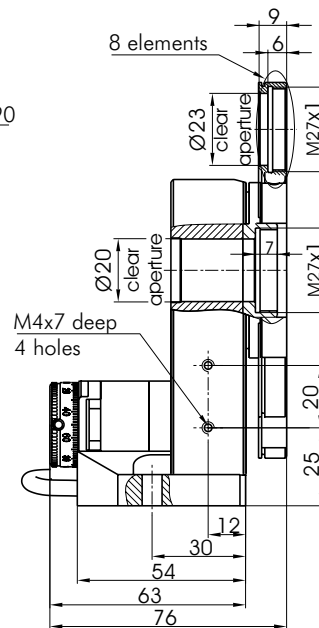
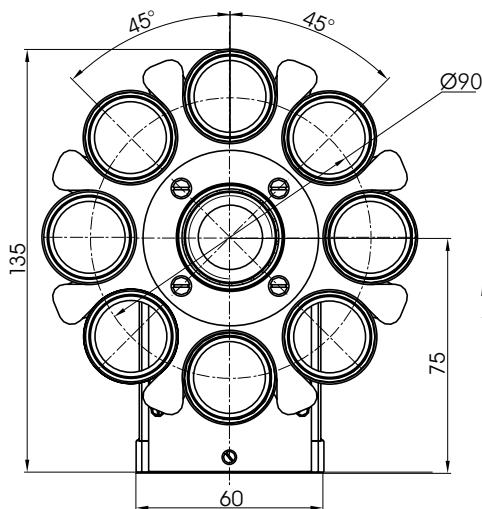

A filter wheel version of universal rotation stage 8MRU. Accepts up to eight 1" filters.

Weight 0.65 kg

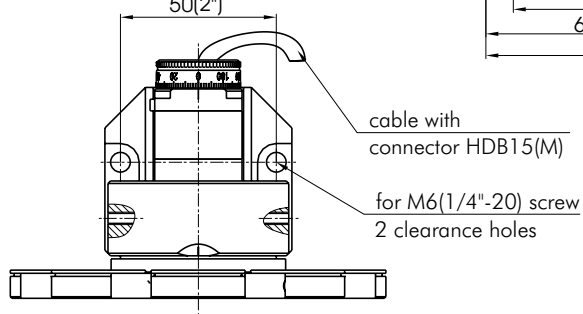

Universal Motorized Rotation Stage

8MRU-1TP

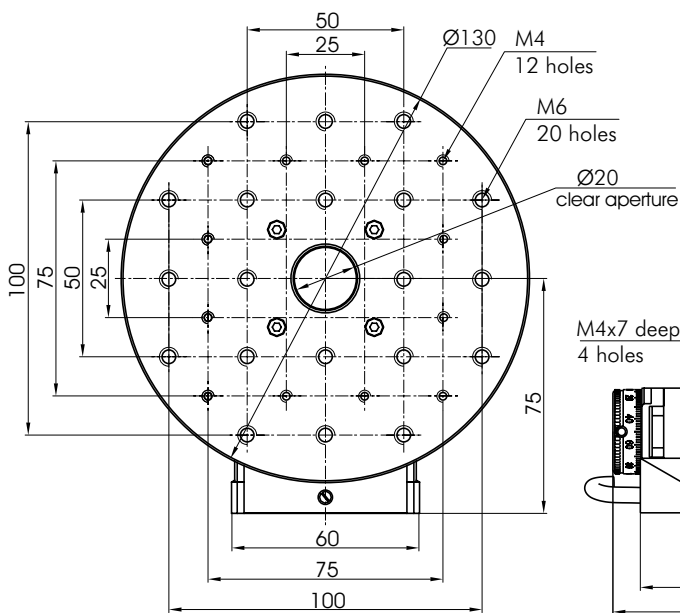

A version of 8MRU with a universal mounting platform with a pattern of M6 and M4 tapped holes.

Weight 0.7 kg

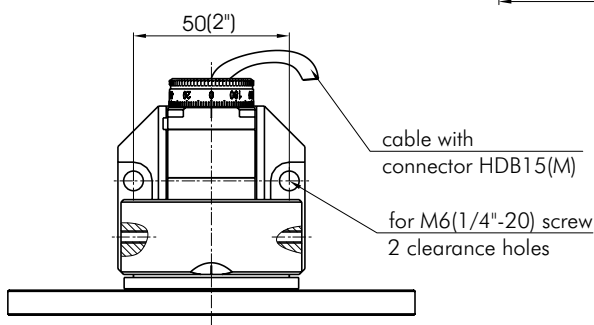
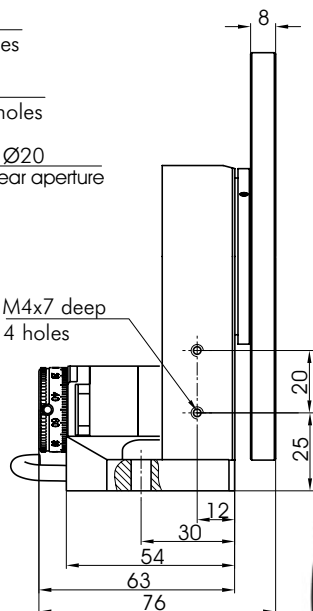

http://www.standa.it

e-mail: sales@standa.it



Phone: +370-5-2651483

Fax: +370-5-2651474



standa



Optical
Tables

1

Brackets
& Rails

2

Base
Mounts &
Accessories

3

Optical
Mounts

4

Optical
Positioners

5

Base
Positioners

6

Translation &
Rotation
Stages

7

Motorised
Positioners &
Controllers

8

Fine
Adjustment
Screws

9

Opto-
Mechanics &
Sets

10

Light Test &
Measurement
Instruments

11