

# Motorized Fiber Coupling Stage

**8MTF2**

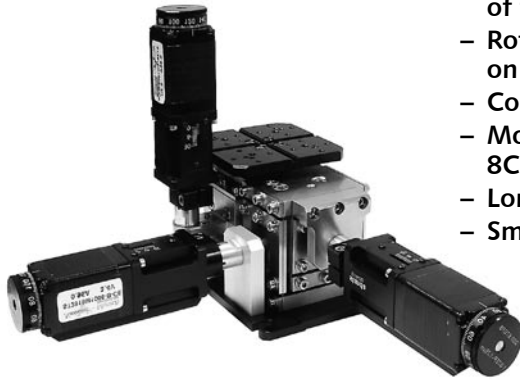

- Fiber coupling stage of flexure design
- Rotating platform on the top
- Compact block design
- Motorized Actuator 8CMA28-10
- Long-term stability
- Smooth motion

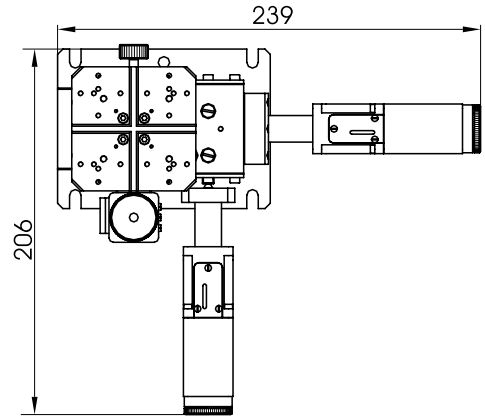
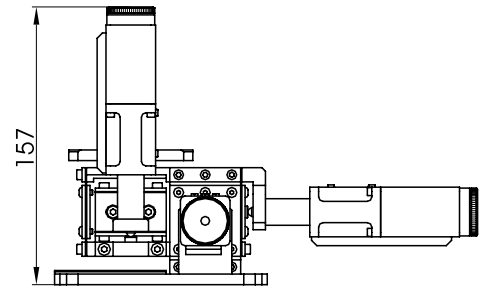

Other dimensions such as 7TF2 (page 7-25)

## SPECIFICATIONS

Travel range in each XYZ direction	2 mm
Resolution	0.2 $\mu$ m
Cross-Talk	20 $\mu$ m/mm
Mechanical stability	flexure design with Stainless Steel Spring
Load capacity	1.5 kg
Type of actuator	8CMA28-10
Cable	1.2 m length cable included
Motor connector	DB15(M)
Weight	1.6 kg

**8SMC1-USBhF programming toolkit for Microsoft Windows Mobile 5.0 is now available!**

## Accessories for Fiber Coupling Stage

page 7-26



7FA1



7FA2



7FA3



7FA4



7FA5

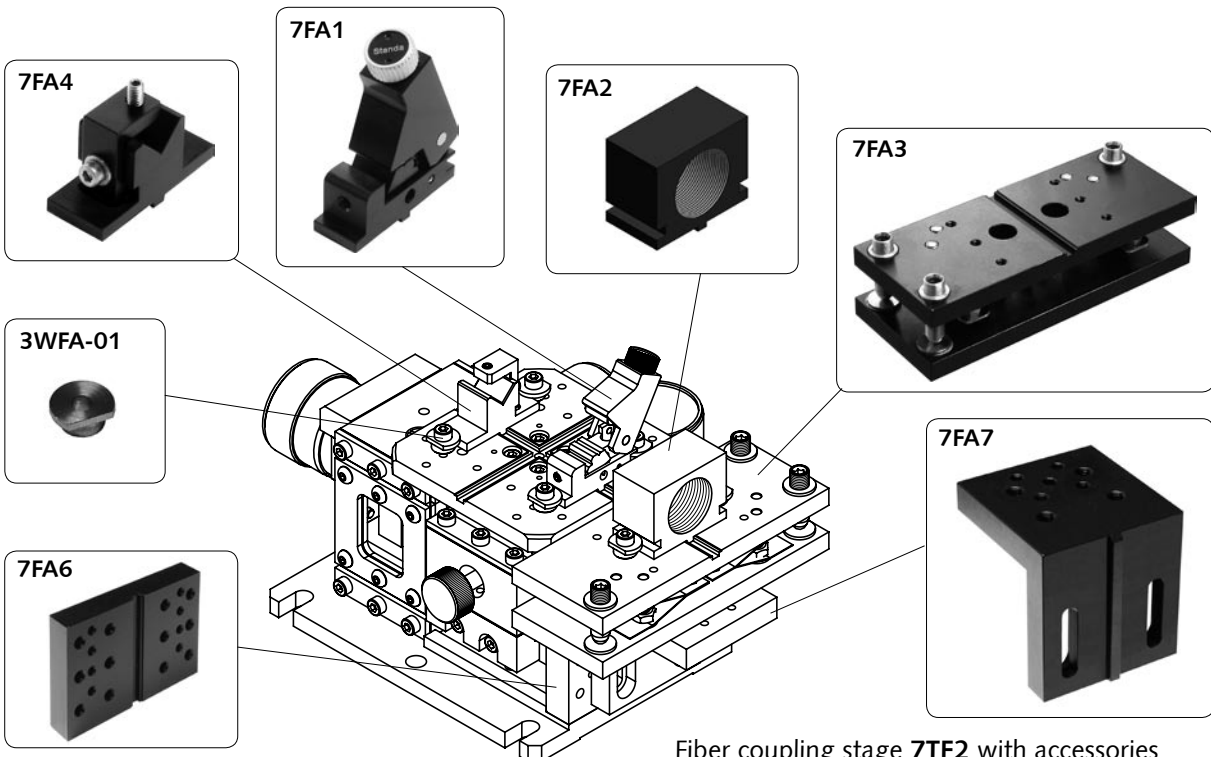

Fiber coupling stage 7TF2 with accessories



http://www.standa.it

e-mail: sales@standa.it



Fax: +370-5-2651483

Phone: +370-5-2651474



**standa**



- Optical Tables 1
- Brackets & Rails 2
- Base Mounts & Accessories 3
- Optical Mounts 4
- Optical Positioners 5
- Base Positioners 6
- Translation & Rotation Stages 7
- Motorised Positioners & Controllers 8
- Fine Adjustment Screws 9
- Opto-Mechanics & Sets 10
- Light Test & Measurement Instruments 11